



Eveready Battery Company, Inc.
Checkerboard Square
St. Louis, MO 63164
Telephone: 1-800-383-7323
Internet: www.energizer.com

Engineering Data

EVEREADY NO. EDL6A

Chemical System: Alkaline-Manganese Dioxide (Zn/MnO_2)
Industrial Lock Pack
Battery Voltage: 9.0 Volts
Terminal: Quick Disconnect
Typical Weight: 150.1 grams (5.3 oz.)
Volume: 47.3 cubic centimeters (2.9 cubic inch)
Average Service Capacity (to 0.8 Volt / cell): 2.9 Ah
(Rated capacity at 25 mA continuous drain)
Cells: Six 3-315IVP in series.

Dimensions (mm)

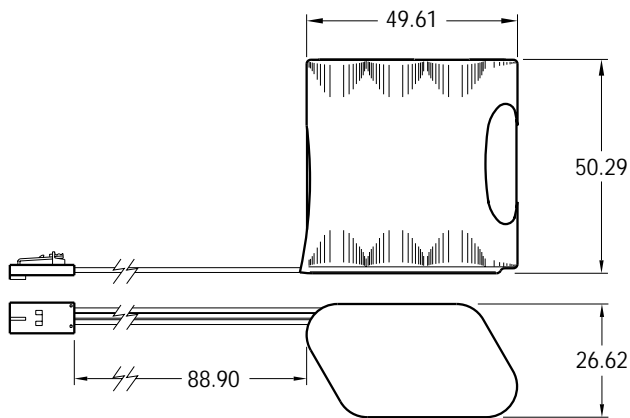

Millimeters	Inches
26.62	1.048
49.61	1.953
50.29	1.980
88.90	3.500

IMPORTANT NOTICE

This data sheet contains information specific to batteries manufactured at time of its publication. Please contact your Energizer representative for most current information. Contents herein do not constitute a warranty.